

No. 690,462.

Patented Jan. 7, 1902.

P. PIRSCH.  
EXTENSION LADDER.

(Application filed Apr. 4, 1901.)

(No Model.)

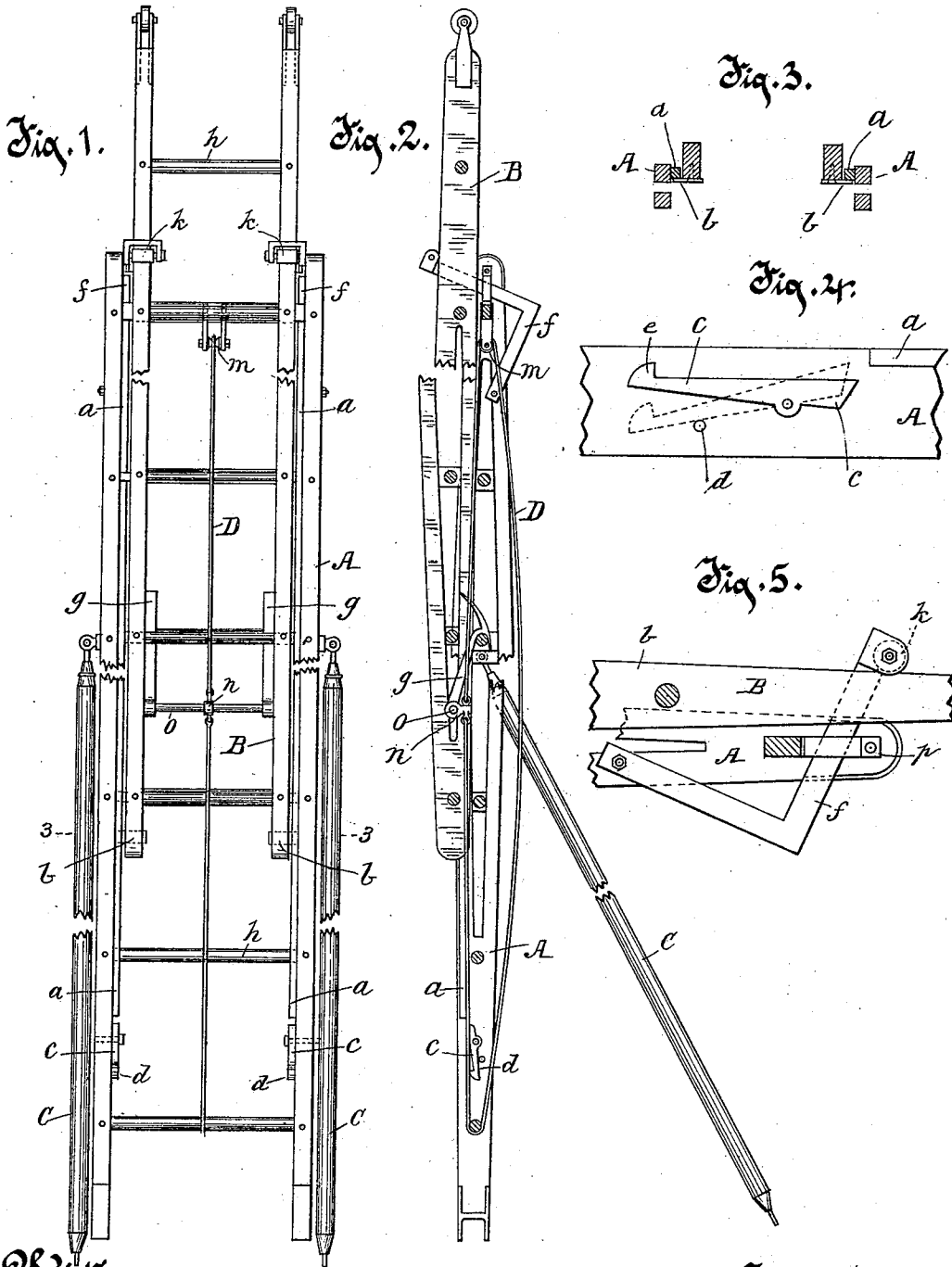

Witnesses:  
O. N. Keeney,  
Erna Schmidt.

Inventor:  
Peter Pirsch  
By Benedict & Morell  
Attorneys.

# UNITED STATES PATENT OFFICE.

PETER PIRSCH, OF KENOSHA, WISCONSIN.

## EXTENSION-LADDER.

SPECIFICATION forming part of Letters Patent No. 690,462, dated January 7, 1902.

Application filed April 4, 1901. Serial No. 54,262. (No model.)

*To all whom it may concern:*

Be it known that I, PETER PIRSCH, residing at Kenosha, in the county of Kenosha and State of Wisconsin, have invented a new and useful Improvement in Extension-Ladders, of which the following is a description, reference being had to the accompanying drawings, which are a part of this specification.

My invention relates to improvements in extension-ladders that are especially adapted for use by hook-and-ladder companies at fires in cities or villages. The object of the present invention is to improve the details of construction of such extension-ladders.

The invention consists of the ladder, its parts, and combinations of parts, as herein described and claimed, or the equivalents thereof.

In the drawings, Figure 1 is an elevation at the front of my improved ladder, parts being broken away for convenience of illustration. Fig. 2 is a side view or elevation of my improved ladder, parts being broken away for convenience of illustration. Fig. 3 is a transverse section on line 3 3 of Fig. 1. Fig. 4 is a detail of a stop employed in my improved ladder. Fig. 5 is a detail of a guide employed in my improved ladder.

My improved ladder is constructed in a plurality of members, ordinarily two, of which one, the member A, is intended and adapted when in use to rest at one end on the ground, and the other member, B, is adapted to slide and be supported on the member A. Each of these members of the ladder consists in a general way of side rails and rungs or rounds *h*. The rails are advisably made of strong and tough wood and with increased width medially, which increased width is cut away centrally for considerable distance, thus making the rails in truss form, whereby they are made as light in weight as possible consistent with the strength required therein. The front edges of the rails of the member A are preferably made substantially straight, and also the rear edges of the member B, and the rounds *h* are fixed in these rails in planes parallel with their straight edges. The extension or fly member B is made narrower than the member A, so as to fit between the rails of the member A and rest and be slidable on the rounds of the member A. For bracing up, and thereby

assisting in supporting the ladder in an upright position, braces C are hinged by a universal joint on the rails of the member A at a distance from its lower extremity and are of such length as to rest on the ground at their lower ends when the ladder is upright or in oblique position.

For raising and lowering the member B on the member A when the members are in an upwardly-extending position a rope D runs over a pulley *m*, mounted between the rails of the member A on a round or cross-bar fixed in the rails of the member, and one end of this rope is secured to a radial arm *n* of a rock-shaft *o*, journaled in the rails of the member B near their lower ends. The rope D at the other side of the pulley *m* runs down and around a round of the member A near its lower extremity and is secured to the radial arm *n*, advisably at a greater distance from the rock-shaft *o* than the point of attachment of the other end of the rope to the same radial arm. The radial arm *n* projects rearwardly from the rock-shaft *o* or away from the front of the ladder, so as not to be in the way of a person going up or down on the ladder, but does not extend so far as to be in the path of the rounds of the member A when the two members are slid along one on the other. A radial arm *g* on the rock-shaft *o* is provided with a terminal hook, so formed that it is adapted by gravity to take onto a round in the member A, and as the member B is slid upwardly on the member A past a round or rounds the rearward extension of the hook is adapted to contact wedgingly with the round and be pressed toward the front of the ladder away from and so as to pass the round in the member A. Also by pulling down on the rear line of the rope D the hook on the radial arm *g* is thrown toward the front out of engagement with the round in the member A and so as to be in position that it will not contact with a round or rounds in the member A as the member B is slid upwardly or downwardly thereon.

For properly guiding the lower extremity of the member B along on the member A, so as to hold it thereto without undue play, a straight rib *a* is secured to the inner side of each rail of the member A, forming ways on the inner or rear surface of the ribs, against

which small plates or lugs *b* bear and travel, these lugs being secured to the rear edges of the rails of the member B near their lower ends. It will be noted that the rails of the member B rest rearwardly on the rounds of the member A and are held thereto slidably by these lugs *b*, bearing toward the front against the ribs or ways *a*. When the member B is to be removed from the member A, the member B is slid down on the member A until the lugs *b* pass below the lower ends of the ways *a*, when the member B can be removed toward the front from the member A.

To prevent the lugs *b* from passing below the ends of the ways *a* and also for supporting the member B on the member A when it is in upright position and not extended beyond the member A, stops *c* are hinged on the inner sides of the rails of the member A in such manner that the upper extremities of the stops normally are in the path of the lugs *b* just at the lower ends of the ways *a*, so that the lugs *b* cannot pass beyond or escape from the ways *a*; but these stops are so located that they can be tilted slightly, rearwardly at the top, permitting the lugs *b* on the member B to pass below the ends of the ways *a* and down alongside of the stops *c*, near to the lower ends of these stops, which are provided with catches *e*, adapted to engage the lugs *b* and prevent the member B from moving downwardly beyond these catches. When the lugs *b* have come down to and rest on the catches *e*, the member B may be removed from the member A toward the front. A pin *d*, fixed in the rail of the member A, prevents the undue tilting of the stop *c*.

For holding the member B movably and removably near to the upper end of the member A, I provide guards *f*, preferably in bent or angle form, pivoted near one extremity on the inner sides of and to the rails of the member A, which guards at their free extremities are turned over the front edges of the rails of the member B and are advisably provided with antifriction-rollers *k*. The construction is such that the rollers *k* bear on the edges of the rails of the member B yieldingly constantly, never projecting in front away from the edges of the rolls, not only when the widest parts of the rails of the member B are opposite the rollers, but also when the member B is slid along so as to bring the narrower parts of the rails opposite the rollers. It will be understood that the rails of the

member B can be run under the rollers *k* on the guards *f* and can be pushed along endwise under those rollers or the member can be completely removed therefrom. Keepers *p*, secured to the member A over the arms *f*, retain those arms against escape from positions for ready use and against lateral strain.

What I claim as my invention is—

1. In combination in extension-ladders, a principal ladder member provided with straight ribways on and along the inner sides of its two rails, an extension or fly ladder member fitting inside the rails of the principal ladder member on the rounds thereof at the front and provided with lugs adapted to bear against and run on the under or rear side of the ways on the other ladder member, and releasable stops on the principal member at the lower ends of the ways and normally in the path of said lugs.

2. In an extension-ladder, a principal ladder member having ribways on the inner sides of its rails, a fly ladder member fitting between the rails of the principal ladder member on its rounds and provided with lugs projecting under said ways, and stops pivoted on the rails of the principal ladder member adjacent to the ends of said ways and disposed to be normally in the path of said lugs preventing them from passing beyond the ways, but being capable of tilting to let the lugs pass and provided with catches adapted to engage and support the fly ladder member when the lugs have passed beyond the ways.

3. In combination in an extension-ladder, two ladder members oneslidable on the other, a rock-shaft in the fly member provided with a radial hook adapted to engage a round of the other member and with a radial arm projecting toward the rear of the fly member, so as to be out of the way of a person going up or down the ladder in front and not extending into the path of the rounds of the other member of the ladder when slid one on the other and a rope attached to said radial arm on the rock-shaft and running thence upwardly over a support in the other ladder member adapted for tilting the rock-shaft and lifting the fly member.

In testimony whereof I affix my signature in presence of two witnesses.

PETER PIRSCH.

Witnesses:

J. C. NEWHOUSE,  
FRED PFISTER.